



0-071-64 - 6 Function LED Rear Combination Lamp RH

Durite's LED 6 Function Rear Combination Lamp:

- Surface Mount
- Multi-voltage alternative for mixed fleet applications
- Highly durable polycarbonate lens, built to withstand the tough working conditions of any commercial vehicle

CE, E Marked ECE Approved.



THE TRUSTED QUALITY BRAND FOR PROFESSIONALS

TECHNICAL SPECIFICATIONS

Type	LED 6 Function Rear Combo Lamp - RH
Voltage	10-30VDC
Functions	STOP / TAIL / DI / REVERSE / FOG / REFLECTOR
Current Draw at 12VDC	Stop 0.2A / Tail 0.35A / DI 0.23A / RE 0.33A / FOG 0.5A
Power	Stop 1.58W/Tail 1.72W/DI 3.18W/ RE 1.57W / FOG 2.75W
IP Rating	IP67
Material Construction	ABS with PC Lens
Weight	0.740Kg
Dimensions	See below diagram
Operating Temperature	-40° ~ 60°C
Fly Lead	500mm
Certificate	CE, ECE E Mark

TECHNICAL DRAWING

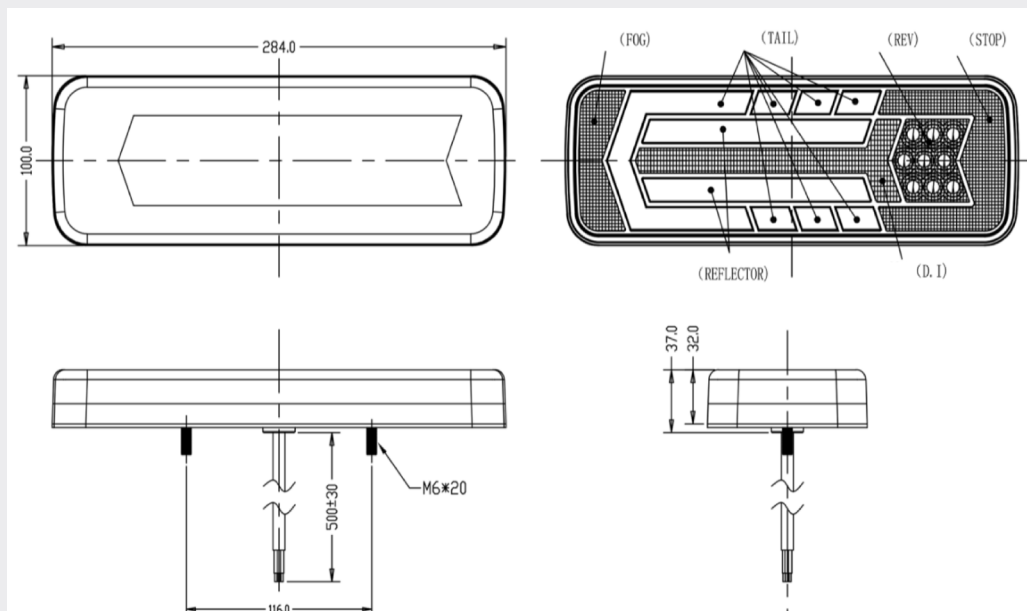

Additional Information:

Wire Colours:

- Red = STOP
- Blue = REVERSE
- Green = FOG
- Yellow = DI
- Brown = FOG